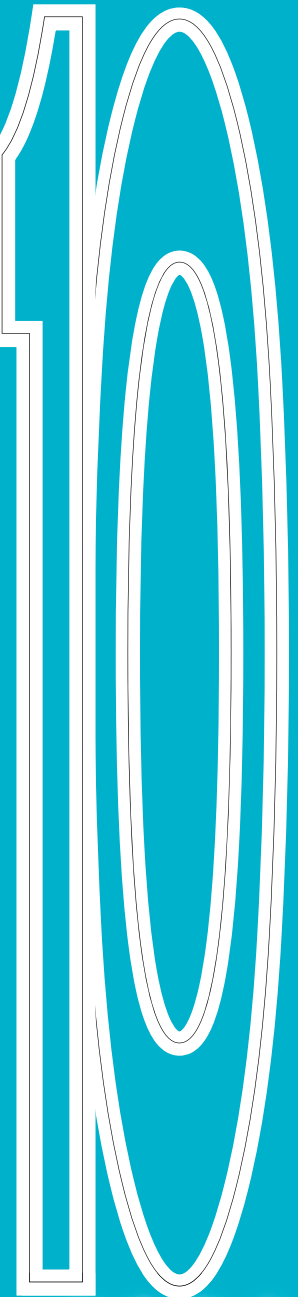


**Texas MUTCD**

# Part

**Traffic Controls for Highway-  
Light Rail Transit  
Grade Crossings**



**2006**



**PART 10. TRAFFIC CONTROLS FOR HIGHWAY-  
LIGHT RAIL TRANSIT GRADE CROSSINGS**

**TABLE OF CONTENTS**

<b><u>SECTIONS</u></b>	<b><u>Page</u></b>
<b>CHAPTER 10A. GENERAL</b>	
Section 10A.01	Introduction .....10A-1
Section 10A.02	Use of Standard Devices, Systems, and Practices .....10A-1
Section 10A.03	Uniform Provisions .....10A-2
Section 10A.04	Highway-Light Rail Transit Grade Crossing Elimination .....10A-2
Section 10A.05	Temporary Traffic Control Zones .....10A-2
<b>CHAPTER 10B. HIGHWAY-LIGHT RAIL TRANSIT GRADE CROSSING CONTROL SYSTEMS</b>	
Section 10B.01	Introduction .....10B-1
<b>CHAPTER 10C. SIGNS, ILLUMINATION, AND MARKINGS</b>	
Section 10C.01	Purpose .....10C-1
Section 10C.02	Highway-Rail Grade Crossing (Crossbuck) Sign (R15-1) and Number of Tracks Sign (R15-2) .....10C-1
Section 10C.03	LOOK Sign (R15-8).....10C-2
Section 10C.04	STOP (R1-1) or YIELD (R1-2) Signs at Highway-Light Rail Transit Grade Crossings ..10C-2
Section 10C.05	DO NOT STOP ON TRACKS Sign (R8-8).....10C-4
Section 10C.06	TRACKS OUT OF SERVICE Sign (R8-9) .....10C-4
Section 10C.07	STOP HERE ON RED Sign (R10-6).....10C-4
Section 10C.08	STOP HERE WHEN FLASHING Sign (R8-10).....10C-4
Section 10C.09	Light Rail Transit-Activated Blank-Out Turn Prohibition Signs (R3-1a, R3-2a).....10C-4
Section 10C.10	EXEMPT Highway-Rail Grade Crossing Sign (R15-3, W10-1a) .....10C-5
Section 10C.11	Divided Highway with Light Rail Transit Crossing Signs (R15-7 Series).....10C-5
Section 10C.12	No Vehicles On Tracks Signs (R15-6, R15-6a) .....10C-5
Section 10C.13	Light Rail Transit Only Lane Signs (R15-4 Series).....10C-6
Section 10C.14	Do Not Pass Light Rail Transit Signs (R15-5, R15-5a).....10C-6
Section 10C.15	Highway-Rail Grade Crossing Advance Warning Signs (W10 Series) .....10C-6
Section 10C.16	Low Ground Clearance Highway-Rail Grade Crossing Sign (W10-5) .....10C-7
Section 10C.17	Light Rail Transit Approaching-Activated Blank-Out Warning Sign (W10-7) .....10C-8
Section 10C.18	Storage Space Signs (W10-11, W10-11a, W10-11b) .....10C-8
Section 10C.19	Skewed Crossing Sign (W10-12).....10C-8
Section 10C.20	Light Rail Transit Station Sign (I-12) .....10C-8
Section 10C.21	Emergency Notification Signs (I-13T or R15-4) .....10C-8
Section 10C.22	Illumination at Highway-Light Rail Transit Crossings.....10C-8
Section 10C.23	Pavement Markings .....10C-9
Section 10C.24	Stop Lines.....10C-9
Section 10C.25	Dynamic Envelope Markings .....10C-9
<b>CHAPTER 10D. HIGHWAY-LIGHT RAIL TRANSIT ACTIVE TRAFFIC CONTROL GRADE CROSSING SYSTEMS</b>	
Section 10D.01	Introduction .....10D-1
Section 10D.02	Flashing-Light Signals .....10D-1
Section 10D.03	Automatic Gates.....10D-1

Section 10D.04	Four-Quadrant Gate Systems .....	10D-2
Section 10D.05	Traffic Control Signals .....	10D-3
Section 10D.06	Highway Traffic Signal Preemption Turning Restrictions.....	10D-4
Section 10D.07	Use of Traffic Control Signals for Control of Light Rail Transit Vehicles at Grade Crossings .....	10D-4
Section 10D.08	Pedestrian and Bicycle Signals and Crossings .....	10D-6

## **FIGURES**

### **CHAPTER 10C. SIGNS, ILLUMINATION, AND MARKINGS**

Figure 10C-1	Highway-Rail Grade Crossing (Crossbuck) Regulatory Signs .....	10C-2
Figure 10C-2	Regulatory Signs .....	10C-3
Figure 10C-3	Warning Signs and Light Rail Station Sign .....	10C-7
Figure 10C-4	Emergency Notification Signs.....	10C-9
Figure 10C-5	Example of Placement of Warning Signs and Pavement Markings at Highway-Light Rail Transit Grade Crossings.....	10C-10
Figure 10C-6	Examples of Highway-Light Rail Transit Grade Crossing Pavement Markings.....	10C-11
Figure 10C-7	Light Rail Transit Vehicle Dynamic Envelope.....	10C-12
Figure 10C-8	Typical Light Rail Transit Vehicle Dynamic Envelope Pavement Markings.....	10C-12
Figure 10C-9	Example of Light Rail Transit Vehicle Dynamic Envelope Pavement Markings.....	10C-13
Figure 10C-10	Example of Light Rail Transit Vehicle Dynamic Envelope Contrasting Color and/or Texture .....	10C-13

### **CHAPTER 10D. HIGHWAY-LIGHT RAIL TRANSIT ACTIVE TRAFFIC CONTROL GRADE CROSSING SYSTEMS**

Figure 10D-1	Examples of Light Rail Transit Signals .....	10D-5
Figure 10D-2	Example of Light Rail Transit Flashing-Light Signal Assembly for Pedestrian Crossings .....	10D-7
Figure 10D-3	Example of Pedestrian Gate Placement Behind the Sidewalk.....	10D-8
Figure 10D-4	Example of Pedestrian Gate Placement with Pedestrian Gate Arm .....	10D-8
Figure 10D-5	Examples of Placement of Pedestrian Gates .....	10D-9
Figure 10D-6	Example of Swing Gates.....	10D-10
Figure 10D-7	Example of Pedestrian Barriers at an Offset Highway-Light Rail Transit Crossing.....	10D-10
Figure 10D-8	Examples of Pedestrian Barrier Installation at an Offset Nonintersection Light Rail Transit Crossing.....	10D-11

## CHAPTER 10A. GENERAL

### **Section 10A.01 Introduction**

#### **Support:**

Part 10 provides standards and guidelines for the design, installation, and operation of traffic control devices at grade crossings of highway traffic and light rail transit vehicles to facilitate the reasonably safe, orderly, and integrated movement of all traffic. The principles in Section 8A.01 are the same but, because light rail vehicles sometimes operate along streets and highways in mixed traffic with automotive vehicles, the traffic controls and associated standards and guidelines for highway-light rail transit grade crossings presented in Part 10 can be different than those presented in Part 8.

Light rail transit is a mode of metropolitan transportation that employs light rail transit vehicles (commonly known as light rail vehicles, streetcars, or trolleys) that operate on rails in streets in mixed traffic, in semiexclusive rights-of-way, or in exclusive rights-of-way. Grade crossings with light rail transit can occur at intersections or at midblock locations, including public and private driveways.

An initial educational campaign along with an ongoing program to continue to educate new drivers is beneficial when introducing light rail operations to an area and, hence, new traffic control devices.

Light rail alignments can be grouped into one of the following three types:

- A. **Exclusive:** A light rail transit right-of-way that is grade-separated or protected by a fence or traffic barrier. Motor vehicles, pedestrians, and bicycles are prohibited within the right-of-way. Subways and aerial structures are included within this group. This type of alignment does not have grade crossings and is not further addressed in Part 10.
- B. **Semiexclusive:** A light rail transit alignment that is in a separate right-of-way or along a street or railroad right-of-way where motor vehicles, pedestrians, and bicycles have limited access and cross at designated locations only.
- C. **Mixed-Use:** An alignment where light rail transit operates in mixed traffic with all types of road users. This includes streets, transit malls, and pedestrian malls where the right-of-way is shared.

#### **Standard:**

**Where light rail transit and railroads use the same tracks or adjacent tracks, the traffic control devices, systems, and practices for highway-rail grade crossings described in Part 8 shall be used.**

#### **Support:**

Section 8A.01 contains a set of definitions, most of which also apply to Part 10.

### **Section 10A.02 Use of Standard Devices, Systems, and Practices**

#### **Support:**

Because of the large number of significant variables to be considered, no single standard system of traffic control devices is universally applicable for all highway-light rail transit grade crossings.

#### **Guidance:**

The appropriate traffic control system to be used at a highway-light rail transit grade crossing should be determined by an engineering study conducted by the transit or highway agency in cooperation with other appropriate State and local organizations.

#### **Standard:**

**Traffic control devices, systems, and practices shall be consistent with the design and application of the Standards contained herein.**

**The traffic control devices, systems, and practices described herein shall be used at all highway-light rail transit grade crossings.**

**Before any new highway-light rail transit grade crossing traffic control system is installed or modifications are made to an existing system, approval shall be obtained from the local agencies having statutory authority to grant such approval.**

#### **Guidance:**

To stimulate effective responses from vehicle operators and pedestrians, these devices, systems, and practices should use the five basic considerations employed generally for traffic control devices and described fully in Section 1A.02: design, placement, operation, maintenance, and uniformity.

Support:

Many other details of highway-light rail transit grade crossing traffic control systems that are not set forth in Part 10 are contained in the publications listed in Section 1A.11.

### **Section 10A.03 Uniform Provisions**

**Standard:**

**All signs used in highway-light rail transit grade crossing traffic control systems shall be retroreflectorized or illuminated as described in Section 2A.08 to show the same shape and similar color to an approaching road user during both day and night.**

**No sign or signal shall be located in the center of an undivided highway, except in a raised island.**

Guidance:

Such signs or signals should be installed with a clearance of at least 2 ft from outer edge of the raised island to the nearest edge of the sign or signal, except as allowed in Section 2A.19.

Where the distance between tracks, measured along the highway between the inside rails, exceeds 100 ft., additional signs or other appropriate traffic control devices should be used.

### **Section 10A.04 Highway-Light Rail Transit Grade Crossing Elimination**

Guidance:

Because highway-light rail transit grade crossings are a potential source of crashes and congestion, agencies should conduct engineering studies to determine the cost and benefits of eliminating these crossings.

**Standard:**

**When a highway-light rail transit grade crossing is eliminated, the traffic control devices for the crossing shall be removed.**

**If the existing traffic control devices at a multiple-track highway-light rail transit grade crossing become improperly placed or inaccurate because of the removal of some of the tracks, the existing devices shall be relocated and/or modified.**

Guidance:

Where a roadway is removed from a highway-light rail transit grade crossing, the roadway approaches in the light rail transit right-of-way should also be removed and appropriate signs should be placed at the roadway end in accordance with Section 3C.04.

Where light rail transit is eliminated at a highway-light rail transit grade crossing, the tracks should be removed or paved over.

Option:

Based on engineering judgment, the TRACKS OUT OF SERVICE (R8-9) sign (see Figure 10C-2) may be temporarily installed until the tracks are removed or paved over. The length of time before the tracks will be removed or paved over may be considered in making the decision as to whether to install the sign.

### **Section 10A.05 Temporary Traffic Control Zones**

Support:

Temporary traffic control planning provides for continuity of operations (such as movement of traffic, pedestrians and bicycles, transit operations, and access to property/utilities) when the normal function of a roadway at a highway-light rail transit grade crossing is suspended because of temporary traffic control operations.

**Standard:**

**Temporary traffic control operations on highways with highway-light rail transit grade crossings shall be as outlined in Part 6.**

**When a highway-light rail transit grade crossing exists either within or in the vicinity of a temporary traffic control zone, lane restrictions, flagging, or other operations shall not be performed in a manner that would cause vehicles to stop on the light rail transit tracks, unless a law enforcement officer or flagger is provided at the highway-light rail transit grade crossing to minimize the possibility of vehicles stopping on the tracks, even if automatic warning devices are in place.**

Guidance:

The agencies responsible for the operation of the light rail transit and highway should be contacted when the initial planning begins for any temporary traffic control zone that may directly or indirectly influence the flow of

traffic on mixed-use facilities where light rail transit and road users operate. Responsible agencies, along with others affected, such as emergency services and businesses, should meet to plan appropriate traffic detours and the necessary signing, marking, and flagging requirements for operations during temporary traffic control activities. Consideration should be given to the length of time that the grade crossing is to be closed, roadway classification, type of vehicle and traffic affected, the time of day, and the materials and techniques of repair.

Temporary traffic control operations should minimize the inconvenience, delay, and crash potential to affected traffic. Prior notice should be given to affected public or private parties, emergency services, businesses, and road users before the free movement of vehicles or light rail transit is infringed on or blocked.

Temporary traffic control activities should not be permitted to extensively prolong the closing of a grade crossing.

The width, grade, alignment, and riding quality of the highway surface at a light rail transit crossing should, at a minimum, be restored to correspond with the quality of the approaches to the highway-light rail transit grade crossing.



## **CHAPTER 10B. HIGHWAY-LIGHT RAIL TRANSIT GRADE CROSSING CONTROL SYSTEMS**

### **Section 10B.01 Introduction**

#### **Support:**

The combination of devices selected or installed at a specific highway-light rail transit grade crossing is referred to as a Light Rail Transit Traffic Control System.

For the safety and integrity of operations by highway and light rail transit users, the highway agency with jurisdiction, the regulatory agency with statutory authority, if applicable, and the light rail transit authority jointly determine the need and selection of traffic control devices and the assignment of priority to light rail transit at a highway-light rail transit grade crossing.

The normal rules of the road and traffic control priority identified in the Uniform Vehicle Code govern the order assigned to the movement of vehicles at an intersection unless the local agency determines that it is appropriate to assign a higher priority to light rail transit. Examples of different types of light rail transit priority control include separate traffic control signal phases for light rail transit movements, restriction of movement of roadway vehicles in favor of light rail transit operations, and preemption of highway traffic signal control to accommodate light rail transit movements.

#### **Standard:**

**Highway-light rail transit grade crossings in semiexclusive alignments shall be equipped with a combination of automatic gates and flashing-light signals, or flashing-light signals only, or traffic control signals, unless an engineering study indicates that the use of STOP, YIELD, or advance warning signs alone would be adequate.**

#### **Option:**

Highway-light rail transit grade crossings in mixed-use alignments may be equipped with traffic control signals unless an engineering study indicates that the use of STOP, YIELD, or advance warning signs alone would be adequate.

#### **Support:**

Section 10C.04 describes the appropriate conditions for the use of STOP or YIELD signs alone at a highway-light rail transit grade crossing.



## CHAPTER 10C. SIGNS, ILLUMINATION, AND MARKINGS

### **Section 10C.01 Purpose**

Support:

Signs and markings regulate, warn, and guide the road users so that they, as well as light rail transit vehicle operators, can take appropriate action.

**Standard:**

**The design and location of signs shall conform to Part 2.**

Support:

Section 8B.02 contains information regarding the sizes of signs for grade crossings.

### **Section 10C.02 Highway-Rail Grade Crossing (Crossbuck) Sign (R15-1) and Number of Tracks Sign (R15-2)**

**Standard:**

**The Highway-Rail Grade Crossing (R15-1) sign, commonly identified as the Crossbuck sign, shall be retroreflectorized white with the words RAILROAD CROSSING in black lettering, mounted as shown in Figure 10C-1.**

**As a minimum, one Crossbuck sign shall be used on each highway approach to every highway-light rail transit grade crossing on a semiexclusive alignment, alone or in combination with other traffic control devices.**

Option:

A Crossbuck sign may be used on a highway approach to a highway-light rail transit grade crossing on a mixed-use alignment, alone or in combination with other traffic control devices.

**Standard:**

**If automatic gates are not present where a Crossbuck sign is being used and if there are two or more tracks at the highway-light rail transit grade crossing, the number of tracks shall be indicated on a supplemental Number of Tracks (R15-2) sign of inverted T shape mounted below the Crossbuck sign in the manner and at the height indicated in Figure 10C-1.**

Option:

The supplemental Number of Tracks sign may also be used at highway-light rail transit grade crossings with automatic gates.

**Standard:**

**If used, the Crossbuck sign shall be installed on the right side of the highway on each approach to the highway-light rail transit grade crossing. Where restricted sight distance or unfavorable highway geometry exists on an approach to a highway-light rail transit grade crossing, an additional Crossbuck sign shall be installed on the left side of the highway, possibly placed back-to-back with the Crossbuck sign for the opposite approach, or otherwise located so that two Crossbuck signs are displayed for that approach.**

**A strip of retroreflective white material not less than 2 inches in width shall be used on the back of each blade of each Crossbuck sign for the length of each blade, at all highway-light rail transit grade crossings, except those where Crossbuck signs have been installed back-to-back.**

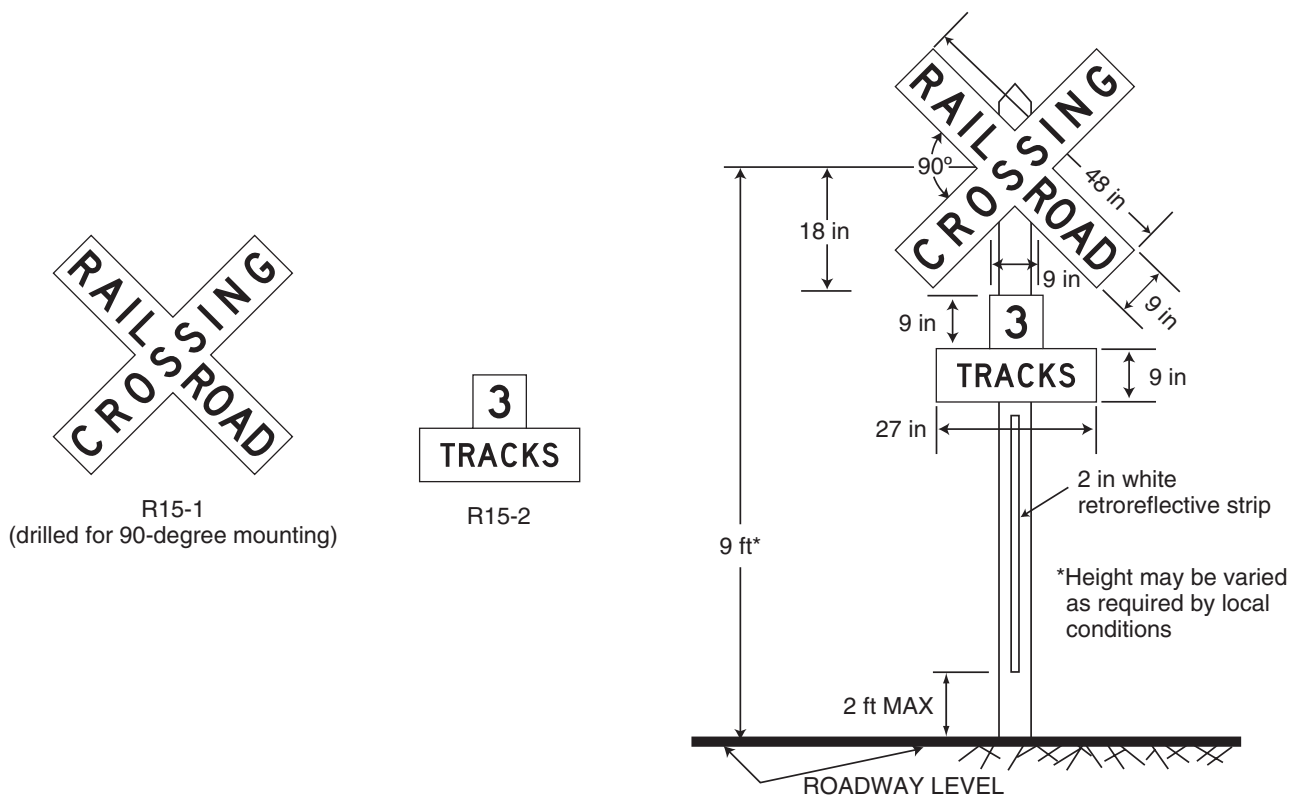
**A strip of retroreflective white material, not less than 2 inches in width, shall be used on each support at passive highway-light rail transit grade crossings for the full length of the front and back of the support from the Crossbuck sign or Number of Tracks sign to within 2 ft. above the edge of the roadway, except on the side of those supports where a STOP (R1-1) or YIELD (R1-2) sign or flashing lights have been installed or on the back side of supports for Crossbuck signs installed on one-way streets.**

Guidance:

If used, Crossbuck signs should be located with respect to the highway pavement or shoulder in accordance with the criteria in Chapter 2A and Figures 2A-1 and 2A-2, and should be located with respect to the nearest track in accordance with Figure 8D-2.

The minimum lateral clearance for the nearest edge of the Crossbuck sign should be 6 ft. from the edge of the shoulder or 12 ft. from the edge of the traveled way in rural areas, and 2 ft. from the face of the curb in urban areas.

**Figure 10C-1. Highway-Rail Grade Crossing (Crossbuck) Regulatory Signs**



Where unusual conditions make variations in location and lateral clearance appropriate, engineering judgment should be used to provide the best practical combination of view and safety clearances.

### **Section 10C.03 LOOK Sign (R15-8)**

Option:

A LOOK (for light rail transit vehicles) (R15-8) sign (see Figure 10C-2) may be mounted at highway-light rail transit grade crossings as a supplemental plaque on the Crossbuck (R15-1) sign post, or as a separate sign in the immediate vicinity of the highway-light rail transit grade crossing on the light rail transit right-of-way.

### **Section 10C.04 STOP (R1-1) or YIELD (R1-2) Signs at Highway-Light Rail Transit Grade Crossings**

**Standard:**

For all highway-light rail transit grade crossings where STOP (R1-1) or YIELD (R1-2) signs are installed, the placement shall conform to the requirements of Sections 2B.06 and 2B.10. Stop Ahead (W3-1) or Yield Ahead (W3-2) Advance Warning signs (see Figure 2C-4) shall also be installed if the criteria for their installation given in Section 2C.29 is met.

Guidance:

The use of STOP or YIELD signs for road users at highway-light rail transit grade crossings should be limited to those crossings where the need and feasibility is established by an engineering study. Such crossings should have all of the following characteristics:

- The crossing roadways should be secondary in character (such as a minor street with one lane in each direction, an alley, or a driveway) with low traffic volumes and low speed limits. The specific thresholds of traffic volumes and speed limits should be determined by the local agencies.
- Light rail transit speeds do not exceed 25 mph.
- The line of sight for an approaching light rail transit operator is adequate from a sufficient distance such that the operator can sound an audible signal and bring the light rail transit vehicle to a stop before

**Figure 10C-2. Regulatory Signs**



R3-1a  
Activated Blank-Out



R3-2a  
Activated Blank-Out



R8-8



R8-9



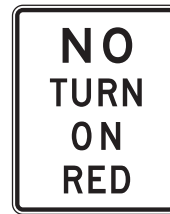
R15-3



R8-10



R10-6



R10-11a



R15-4a



R15-4b



R15-4c



R15-5



R15-5a



R15-6



R15-6a



R15-7



R15-7a



R15-8

arriving at the crossing.

- D. The road user has sufficient sight distance at the stop line to permit the vehicle to cross the tracks before the arrival of the light rail transit vehicle.
- E. If at an intersection of two roadways, the intersection does not meet the warrants for a traffic control signal as specified in Chapter 4C.
- F. The light rail transit tracks are located such that vehicles are not likely to stop on the tracks while waiting to enter a cross street or highway.

If a STOP or YIELD sign is installed beyond the light rail transit crossing such that vehicle queues are likely to extend into the path of the light rail transit, a DO NOT STOP ON TRACKS sign (R8-8) should be posted in accordance with Section 10C.05.

**Option:**

If a STOP or YIELD sign is installed at a highway-light rail transit grade crossing, it may be installed on the Crossbuck post or on a separate post at the point where the vehicle is to stop, or as near to that point as practical.

**Section 10C.05 DO NOT STOP ON TRACKS Sign (R8-8)****Guidance:**

A DO NOT STOP ON TRACKS (R8-8) sign (see Figure 10C-2) should be installed whenever an engineering study determines that the potential for vehicles stopping on the tracks at a highway-light rail transit grade crossing is significant. Placement of the R8-8 sign should be determined as part of the engineering study. The sign, if used, should be located on the right side of the highway on either the near or far side of the grade crossing, depending upon which position provides better visibility to approaching drivers.

**Option:**

DO NOT STOP ON TRACKS signs may be placed on both sides of the track.

On divided highways and one-way streets, a second DO NOT STOP ON TRACKS sign may be placed on the near or far left side of the highway at the grade crossing to further improve visibility of the sign.

**Section 10C.06 TRACKS OUT OF SERVICE Sign (R8-9)****Option:**

The TRACKS OUT OF SERVICE (R8-9) sign (see Figure 10C-2) may be used at a highway-light rail transit grade crossing instead of a Crossbuck (R15-1) sign and a Number of Tracks (R15-2) sign when light rail transit tracks have been temporarily or permanently abandoned, but only until such time that the tracks are removed or paved over.

**Standard:**

**When tracks are out of service, traffic control devices and gate arms shall be removed and the signal heads shall be removed or hooded or turned from view to clearly indicate that they are not in operation.**

**The R8-9 sign shall be removed when the tracks have been removed or covered or when the highway-light rail transit grade crossing is returned to service.**

**Section 10C.07 STOP HERE ON RED Sign (R10-6)****Support:**

The STOP HERE ON RED (R10-6) sign (see Figure 10C-2) defines and facilitates observance of the stop lines at traffic control signals.

**Option:**

A STOP HERE ON RED sign may be used at locations where vehicles frequently violate the stop line or where it is not obvious to road users where to stop.

**Guidance:**

If possible, stop lines should be placed at a point where the vehicle driver has adequate sight distance along the track.

**Section 10C.08 STOP HERE WHEN FLASHING Sign (R8-10)****Option:**

The STOP HERE WHEN FLASHING (R8-10) sign (see Figure 10C-2) may be used at a highway-light rail transit grade crossing to inform drivers of the location of the stop line or the point at which to stop when the flashing-light signals (see Section 10D.02) are activated.

**Section 10C.09 Light Rail Transit-Activated Blank-Out Turn Prohibition Signs (R3-1a, R3-2a)****Support:**

Light rail transit operations can include the use of activated blank-out sign technology for turn prohibition (R3-1a, R3-2a) signs (see Figure 10C-2). The signs are typically used on roads paralleling a semiexclusive or mixed-use light rail transit alignment where road users might turn across the light rail transit tracks. A blank-out sign displays its message only when activated. When not activated, the sign face is blank.

**Guidance:**

A light rail transit-activated blank-out turn prohibition sign should be used where an intersection adjacent to a highway-light rail transit crossing is controlled by STOP signs, or is controlled by traffic control signals with permissive turn movements for road users crossing the tracks.

**Option:**

A light rail transit-activated blank-out turn prohibition sign may be used for turning movements that cross the tracks.

As an alternative to light rail transit-activated blank-out turn prohibition signs at intersections with traffic control signals, exclusive traffic control signal phases such that all movements that cross the tracks have a red indication may be used in combination with NO TURN ON RED (R10-11a) signs.

**Standard:**

**Turn prohibition signs that are associated with preemption shall be visible only when the highway-light rail transit grade crossing restriction is in effect.**

**Section 10C.10 EXEMPT Highway-Rail Grade Crossing Sign (R15-3, W10-1a)****Option:**

When authorized by law or regulation, a supplemental EXEMPT (R15-3) sign (see Figure 10C-2) with a white background may be used below the Crossbuck sign or Number of Tracks sign, if present, at the highway-light rail transit grade crossing, and a supplemental EXEMPT (W10-1a) sign (see Figure 10C-3) with a yellow background may be used below the Highway-Rail Advance Warning (W10-1) sign. Where neither the Crossbuck nor the advance warning signs exist for a particular crossing, an EXEMPT (R15-3) sign with a white background may be placed on its own post on the near right side of the approach to the crossing.

**Support:**

These supplemental signs inform drivers of vehicles carrying passengers for hire, school buses carrying students, or vehicles carrying hazardous materials that a stop is not required at certain designated highway-light rail transit grade crossings, except when a light rail transit vehicle is approaching or occupying the highway-light rail transit grade crossing, or the driver's view is blocked.

**Section 10C.11 Divided Highway with Light Rail Transit Crossing Signs (R15-7 Series)****Option:**

The Divided Highway With Light Rail Transit Crossing (R15-7) sign (see Figure 10C-2) may be used as a supplemental sign on the approach legs of a roadway that intersects with a divided highway where light rail transit vehicles operate in the median. The sign may be placed beneath a STOP sign or mounted separately.

**Guidance:**

The number of tracks shown on the R15-7 sign should be the same as the actual number of tracks.

**Standard:**

**When the Divided Highway With Light Rail Transit Crossing sign is used at a four-legged intersection, the R15-7 sign shall be used. When used at a T-intersection, the R15-7a sign shall be used.**

**Section 10C.12 No Vehicles On Tracks Signs (R15-6, R15-6a)****Support:**

The No Vehicles On Tracks (R15-6) sign (see Figure 10C-2) is used where there are adjacent traffic lanes separated from the light rail transit lane by a curb or pavement markings.

**Guidance:**

The DO NOT ENTER (R5-1) sign should be used where a road user could wrongly enter a light rail transit only street.

**Option:**

A No Vehicles On Tracks sign may be used to deter vehicles from driving on the trackway. It may be installed either on a 3 ft flexible post between double tracks, on a post alongside the tracks, or overhead.

Instead of the R15-6 symbol sign, a regulatory sign with the word message DO NOT DRIVE ON TRACKS (R15-6a) may be used (see Figure 10C-2).

A reduced size of 12 x 12 inches may be used if the R15-6 sign is installed between double tracks.

**Standard:**

**The smallest size for the R15-6 sign shall be 12 x 12 inch.**

### **Section 10C.13 Light Rail Transit Only Lane Signs (R15-4 Series)**

#### **Support:**

The Light Rail Transit Only Lane (R15-4 series) signs (see Figure 10C-2) are used for multi-lane operations, where road users might need additional guidance on lane use and/or restrictions.

#### **Option:**

Light Rail Transit Only Lane signs may be used on a roadway lane limited to only light rail transit use to indicate the restricted use of a lane in semiexclusive and mixed alignments.

#### **Guidance:**

If used, the R15-4a, R15-4b, and R15-4c signs should be installed on posts adjacent to the roadway containing the light rail transit tracks or overhead above the light rail transit only lane.

#### **Option:**

If the trackway is paved, preferential lane markings (see Section 3B.22) may be installed but only in combination with light rail transit only lane signs.

#### **Support:**

The trackway is the continuous way designated for light rail transit, including the entire dynamic envelope. Section 10C.25 contains more information regarding the dynamic envelope.

### **Section 10C.14 Do Not Pass Light Rail Transit Signs (R15-5, R15-5a)**

#### **Support:**

A Do Not Pass Light Rail Transit (R15-5) sign (see Figure 10C-2) is used to indicate that vehicles are not allowed to pass light rail transit vehicles that are loading or unloading passengers where there is no raised platform or physical separation from the lanes upon which other motor vehicles are operating.

#### **Option:**

The R15-5 sign may be used in mixed-use alignments and may be mounted overhead where there are multiple lanes.

Instead of the R15-5 symbol sign, a regulatory sign with the word message DO NOT PASS STOPPED TRAIN (R15-5a) may be used (see Figure 10C-2).

#### **Guidance:**

If used, the R15-5 sign should be located immediately before the light rail transit boarding area.

### **Section 10C.15 Highway-Rail Grade Crossing Advance Warning Signs (W10 Series)**

#### **Standard:**

**A Highway-Rail Grade Crossing Advance Warning (W10-1) sign (see Figure 10C-3) shall be used on each highway in advance of every highway-light rail transit grade crossing in semiexclusive alignments except in the following circumstances:**

- A. On an approach to a highway-light rail transit grade crossing from a T-intersection with a parallel highway, if the distance from the edge of the track to the edge of the parallel roadway is less than 100 ft, and W10-3 signs are used on both approaches of the parallel highway; or**
- B. On low-volume, low-speed highways crossing minor spurs or other tracks that are infrequently used and are flagged by transit crews; or**
- C. In business districts where active highway-light rail transit grade crossing traffic control devices are in use; or**
- D. Where physical conditions do not permit even a partially effective display of the sign.**

**Placement of the Highway-Rail Grade Crossing Advance Warning sign shall be in accordance with Chapter 2A and Table 2C-4.**

#### **Option:**

On divided highways and one-way streets, an additional W10-1 sign may be installed on the left side of the roadway.

#### **Standard:**

**If the distance between the light rail transit tracks in a semiexclusive alignment and a parallel highway, from the edge of the tracks to the edge of the parallel roadway, is less than 100 ft., W10-2, W10-3, or W10-4 signs (see Figure 10C-3) shall be installed on each approach of the parallel highway to warn road users making a turn that they will encounter a highway-light rail transit grade crossing soon after**

**Figure 10C-3. Warning Signs and Light Rail Station Sign**

making a turn, and a W10-1 sign for the approach to the tracks shall not be required to be between the tracks and the parallel highway.

If the W10-2, W10-3, or W10-4 signs are used, sign placement in accordance with the guidelines for Intersection Warning signs in Table 2C-4 using the speed of through traffic shall be measured from the highway intersection.

Guidance:

If the distance between the light rail transit tracks and the parallel highway, from the edge of the tracks to the edge of the parallel roadway, is 100 ft. or more, a W10-1 sign should be installed in advance of the highway-light rail transit grade crossing, and the W10-2, W10-3, or W10-4 signs should not be used on the parallel highway.

### **Section 10C.16 Low Ground Clearance Highway-Rail Grade Crossing Sign (W10-5)**

Guidance:

If the highway profile conditions are sufficiently abrupt to create a hang-up situation for long wheelbase vehicles or for trailers with low ground clearance, the Low Ground Clearance Highway-Rail Grade Crossing (W10-5) sign (see Figure 10C-3) should be installed in advance of the highway-light rail transit grade crossing.

Support:

Information regarding the use of the W10-5 sign is contained in Section 8B.17.

### **Section 10C.17 Light Rail Transit Approaching-Activated Blank-Out Warning Sign (W10-7)**

#### Support:

The Light Rail Transit Approaching-Activated Blank-Out (W10-7) warning sign (see Figure 10C-3) supplements the traffic control signal to warn road users turning across the tracks of an approaching parallel light rail transit vehicle.

#### Option:

A Light Rail Transit Approaching-Activated Blank-Out warning sign may be used at signalized intersections near grade crossings or at crossings controlled by STOP signs or automatic gates.

### **Section 10C.18 Storage Space Signs (W10-11, W10-11a, W10-11b)**

#### Guidance:

A Storage Space (W10-11) sign supplemented by a word message storage distance (W10-11a) sign (see Figure 10C-3) should be used where there is a highway intersection in close proximity to the highway-light rail transit grade crossing and an engineering study determines that adequate space is not available to store a design vehicle(s) between the highway intersection and the light rail transit vehicle dynamic envelope.

#### Support:

Information regarding the use of the W10-11, W10-11a, and W10-11b signs is contained in Section 8B.18.

### **Section 10C.19 Skewed Crossing Sign (W10-12)**

#### Option:

The Skewed Crossing (W10-12) sign (see Figure 10C-3) may be used at a skewed highway-light rail transit grade crossing to warn drivers that the light rail transit tracks are not perpendicular to the highway.

#### Support:

Information regarding the use of the W10-12 sign is contained in Section 8B.19.

### **Section 10C.20 Light Rail Transit Station Sign (I-12)**

#### Option:

The Light Rail Transit Station (I-12) sign (see Figure 10C-3) may be used to direct road users to a light rail transit station or boarding location. It may be supplemented by the name of the transit system and by arrows as provided in Section 2D.08.

### **Section 10C.21 Emergency Notification Signs (I-13T or R15-4)**

#### Guidance:

The Emergency Notification (I-13T) sign (see Figure 10C-4) should be installed at all highway-light rail transit grade crossings without flashing lights or automatic gates. It should be attached below the railroad crossbuck sign (R15-1) and have a minimum mounting height of five feet. The sign should have a white message on blue background. One sign should be placed at each location facing the roadway.

The Emergency Notification (R15-4) sign (see Figure 8B-4) should be installed at all highway-light rail transit grade crossings using flashing lights or automatic gates. The sign should have a black message on a white background. It should be attached below the railroad crossbuck sign (R15-1) and have a minimum mounting height of five feet. One sign should be placed for each roadway approach direction.

These signs, which are for notification of emergency or other problems, should convey a clear and simple message that is visible to anyone stalled or disabled on the transit tracks, and to anyone reporting other problems.

### **Section 10C.22 Illumination at Highway-Light Rail Transit Crossings**

#### Guidance:

Where light rail transit operations are conducted at night, illumination at and adjacent to the highway-light rail transit grade crossing should be considered.

#### Support:

Recommended types and location of luminaries for highway-rail (light rail transit) grade crossings are contained in the American National Standards Institute's (ANSI) "Practice for Roadway Lighting RP-8," available from the Illuminating Engineering Society (see Section 1A.11).

**Figure 10C-4. Examples of Emergency Notification Signs**

I-13T



R15-4

**Section 10C.23 Pavement Markings****Standard:**

All highway-light rail transit grade crossing pavement markings shall be retroreflectorized white. All other markings shall be in accordance with Part 3.

Pavement markings in advance of a highway-light rail transit grade crossing shall consist of an X, the letters RR, a no-passing marking (two-lane highways where centerline markings are used), and certain transverse lines as shown in Figures 10C-5 and 10C-6.

Identical markings shall be placed in each approach lane on all paved approaches to highway-light rail transit grade crossings where signals or automatic gates are located, and at all other highway-light rail transit grade crossings where the posted or statutory highway speed is 40 mph or greater.

Pavement markings shall not be required at highway-light rail transit grade crossings where the posted or statutory highway speed is less than 40 mph, or in urban areas, if an engineering study indicates that other installed devices provide suitable warning and control.

**Guidance:**

When pavement markings are used, a portion of the X symbol should be directly opposite the Advance Warning sign. The X symbol and letters should be elongated to allow for the low angle at which they will be viewed.

**Option:**

When justified by engineering judgment, supplemental pavement marking symbol(s) may be placed between the Advance Warning sign and the highway-light rail transit grade crossing.

**Section 10C.24 Stop Lines****Support:**

Information regarding the use of stop lines at grade crossings is contained in Section 8B.21.

**Section 10C.25 Dynamic Envelope Markings****Support:**

The dynamic envelope (see Figure 10C-7) markings indicate the clearance required for the light rail transit vehicle overhang resulting from any combination of loading, lateral motion, or suspension failure.

**Option:**

The dynamic envelope may be delineated on the pavement using pavement markings (see Figures 10C-8 and 10C-9) or contrasting pavement color and/or contrasting pavement texture (see Figure 10C-10).

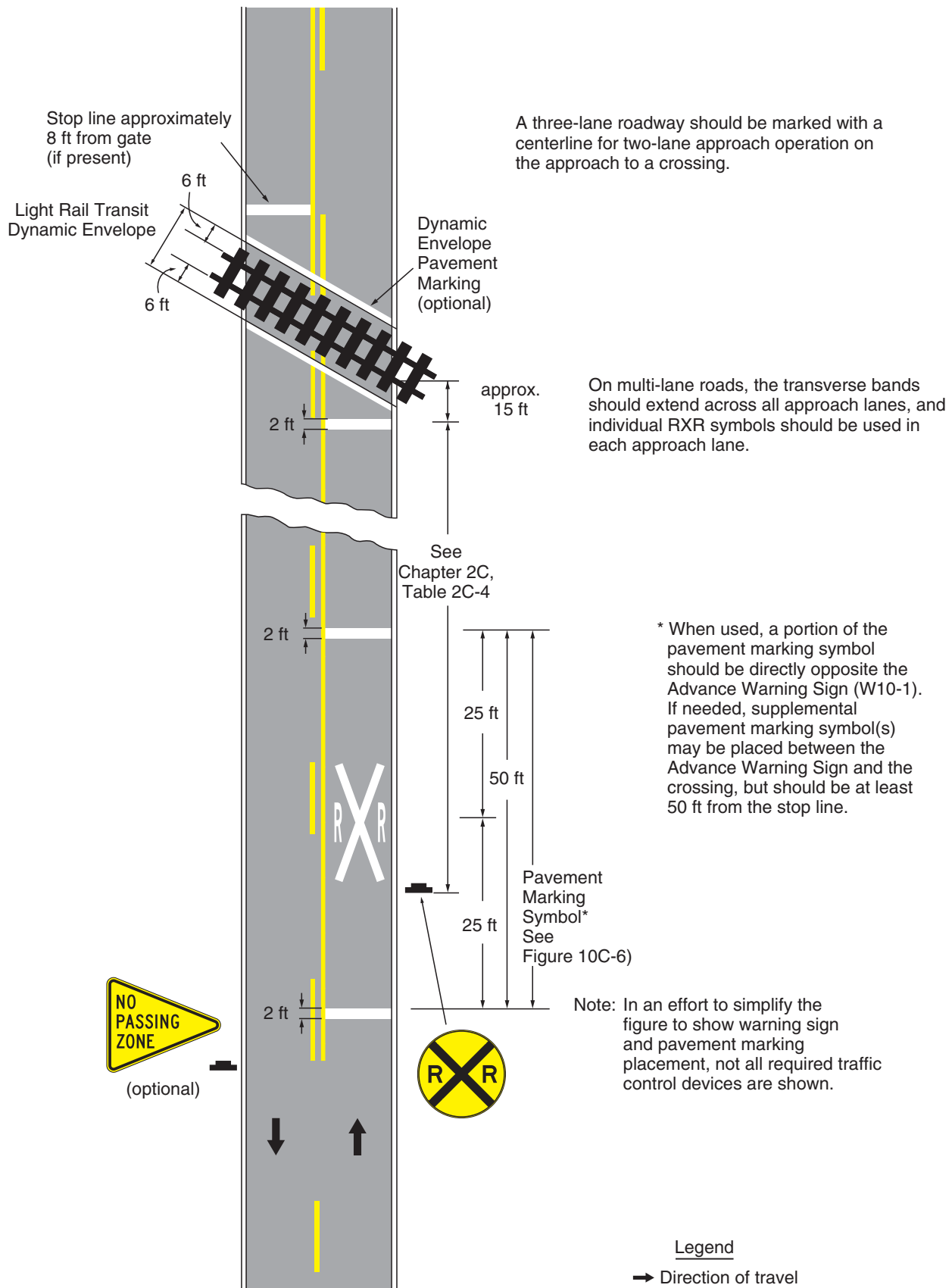
**Standard:**

**If used, pavement markings for indicating the dynamic envelope shall conform to Part 3 and shall be a 4 inch normal solid white line or contrasting pavement color and/or contrasting pavement texture.**

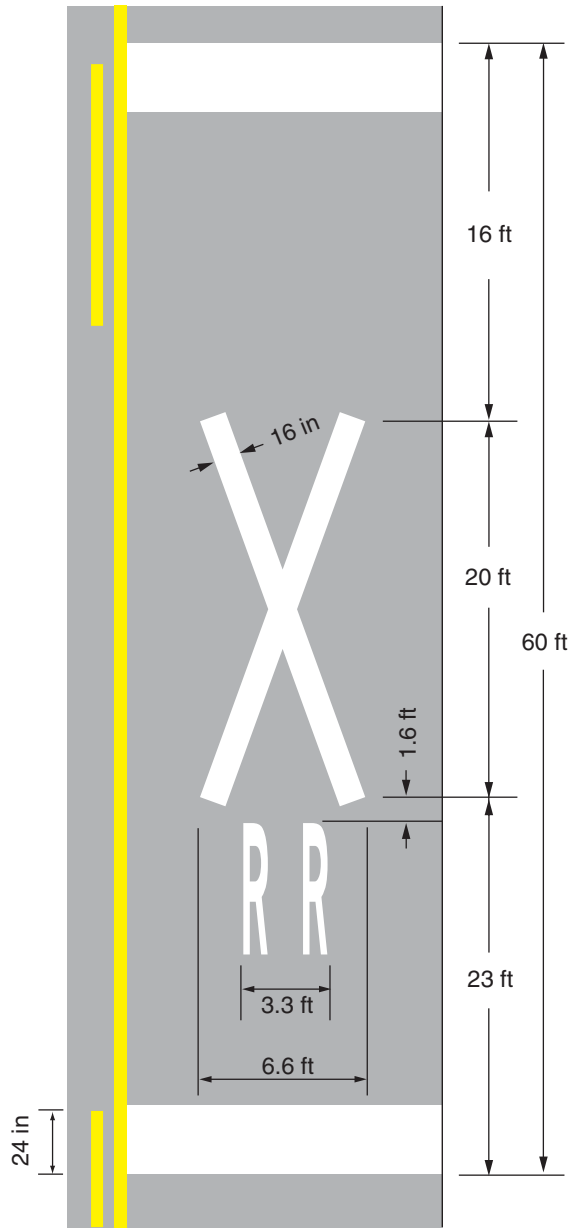
**Guidance:**

If pavement markings are used to convey the dynamic envelope, they should be placed completely outside of the dynamic envelope. If used at light-rail transit grade crossings, dynamic envelope pavement markings should

**Figure 10C-5. Example of Placement of Warning Signs and Pavement Markings at Highway-Light Rail Transit Grade Crossings**

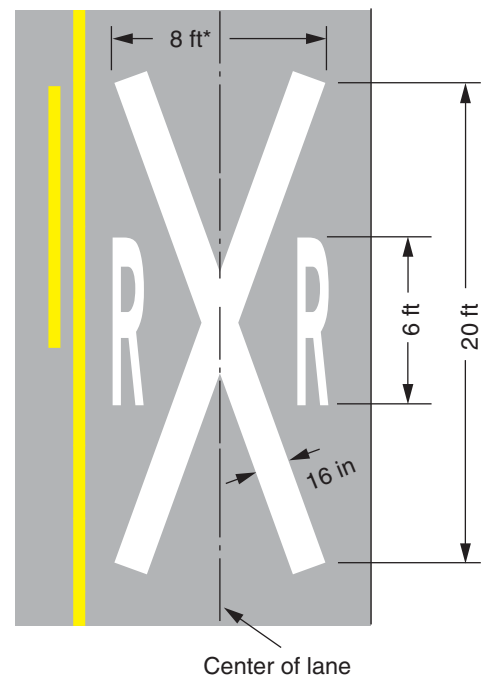


**Figure 10C-6. Examples of Highway-Light Rail Transit Grade Crossing Pavement Markings**



**Highway-Light Rail Transit grade crossing alternative (narrow) pavement markings**

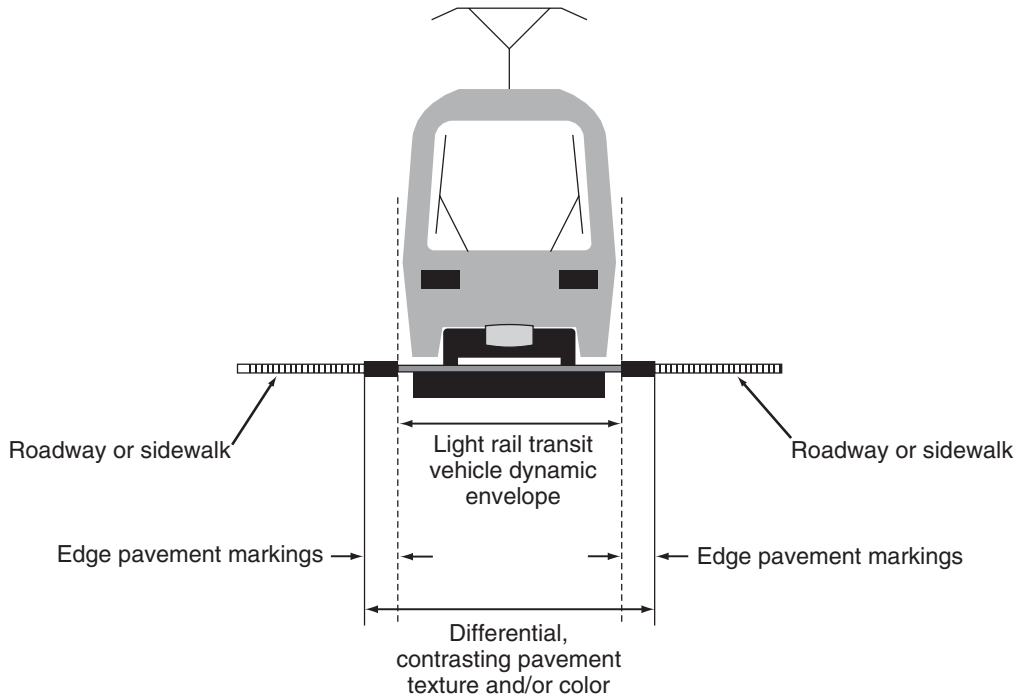
Note: Refer to Figure 10C-5 for placement



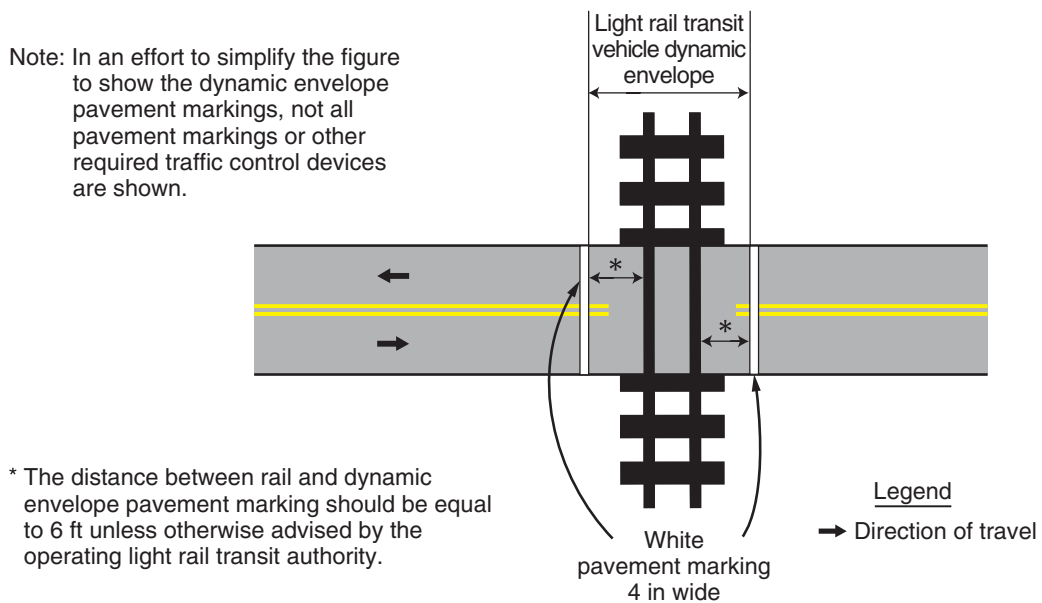
**Highway-Light Rail Transit grade crossing pavement markings**

\*Width may vary according to lane width

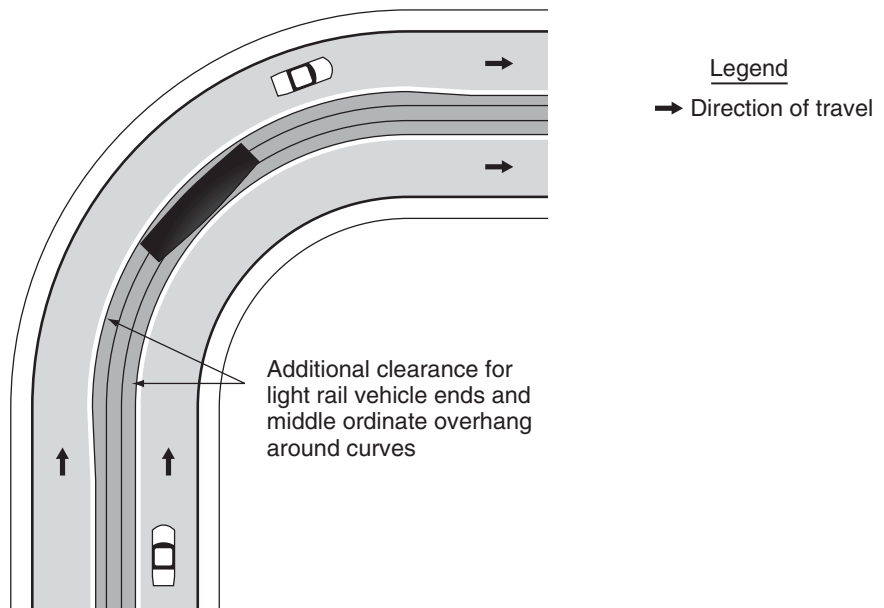
**Figure 10C-7. Light Rail Transit Vehicle Dynamic Envelope**



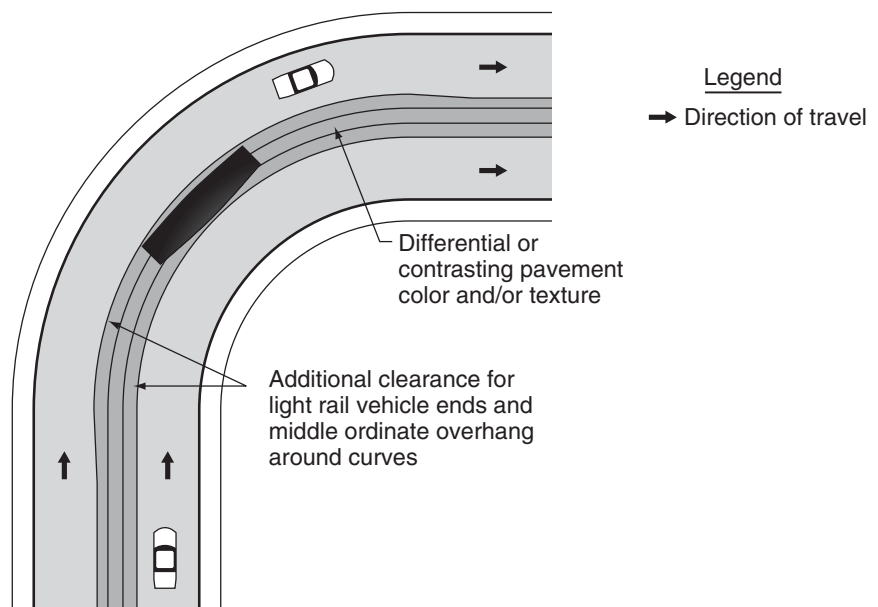
**Figure 10C-8. Typical Light Rail Transit Vehicle Dynamic Envelope Pavement Markings**



**Figure 10C-9. Example of Light Rail Transit Vehicle Dynamic Envelope Pavement Markings**



**Figure 10C-10. Example of Light Rail Transit Vehicle Dynamic Envelope Contrasting Color and/or Texture**



be placed on the highway 6 ft. from the nearest rail and installed parallel to the tracks, unless the transit authority and/or operating company advises otherwise. The pavement markings should extend across the roadway as shown in Figure 10C-8.

Option:

In semiexclusive alignments, the dynamic envelope markings may be along the light rail transit trackway between intersections where the trackway is immediately adjacent to travel lanes and no physical barrier is present.

In mixed-use alignments the dynamic envelope markings may be continuous between intersections.

Dynamic envelope markings may be installed at all highway-light rail transit grade crossings, unless a Four-Quadrant Gate system (see Section 10D.04) is used.

Pavement markings for adjacent travel or parking lanes may be used instead of dynamic envelope markings if the lines are outside the dynamic envelope.

## CHAPTER 10D. HIGHWAY-LIGHT RAIL TRANSIT ACTIVE TRAFFIC CONTROL GRADE CROSSING SYSTEMS

### **Section 10D.01 Introduction**

#### Support:

Active light rail transit traffic control systems inform motorists, bicyclists, and pedestrians of the approach or presence of light rail transit vehicles at highway-light rail transit grade crossings. These systems include four-quadrant gate systems, automatic gates, flashing-light signals, traffic control signals, actuated blank-out and variable message signs, and other active traffic control devices.

#### Guidance:

Where both traffic control signals and flashing-light signals (with or without automatic gates) are in operation at the same highway-light rail transit grade crossing, the operation of the devices should be coordinated to avoid any display of conflicting signal indications.

If a pedestrian route is provided, sufficient clearance from supports, posts, and gate mechanisms should be maintained for pedestrian travel.

#### Option:

Audible devices may be operated in conjunction with the flashing lights or traffic control signals.

#### Support:

Light rail transit typically operates through grade crossings in semiexclusive and mixed-use alignments at speeds between 10 mph and 65 mph.

When light rail transit speed is cited in this Part, it refers to the maximum speed at which light rail transit vehicles are permitted to traverse a particular grade crossing.

### **Section 10D.02 Flashing-Light Signals**

#### Support:

Sections 8D.02 and 8D.03 contain additional details regarding flashing-light signals.

#### Standard:

**Highway-light rail transit grade crossings in semiexclusive alignments shall be equipped with flashing-light signals where light rail transit speeds exceed 35 mph. Flashing-light signals shall be clearly visible to motorists, pedestrians, and bicyclists.**

#### Guidance:

Where the crossing is at a location other than an intersection, where light rail transit speeds exceed 25 mph, flashing-light signals should be installed.

#### Option:

Traffic control signals may be used instead of flashing-light signals at highway-light rail transit grade crossings within highway-highway intersections where light rail transit speeds do not exceed 35 mph. Traffic control signals or flashing-light signals may be used where the crossing is at a location other than an intersection, where light rail transit speeds do not exceed 25 mph, and when the roadway is a low-volume street where prevailing speeds do not exceed 25 mph.

### **Section 10D.03 Automatic Gates**

#### Support:

An automatic gate is a traffic control device used as an adjunct to flashing-light signals.

Section 8D.04 contains further details regarding automatic gates.

#### Guidance:

Highway-light rail transit grade crossings in semiexclusive alignments should be equipped with automatic gates and flashing-light signals (see Section 10D.02) where light rail transit speeds exceed 35 mph.

#### Option:

Where the grade crossing is at a location other than an intersection, where light rail transit speeds exceed 25 mph, automatic gates and flashing-light signals may be installed.

Traffic control signals may be used instead of automatic gates at highway-light rail transit grade crossings within highway-highway intersections where light rail transit speeds do not exceed 35 mph. Traffic control signals or flashing-light signals without automatic gates may be used where the crossing is at a location other

than an intersection and where light rail transit speeds do not exceed 25 mph and the roadway is a low-volume street where prevailing speeds do not exceed 25 mph.

Automatic gates may be supplemented by cantilevered flashing-light signals (see Figure 8D-1) where there is a need for additional emphasis or better visibility.

The effectiveness of gates may be enhanced by the use of channelizing devices or raised median islands to discourage driving around lowered automatic gates.

#### **Section 10D.04 Four-Quadrant Gate Systems**

Option:

Four-Quadrant Gate systems may be installed to improve safety at highway-light rail transit grade crossings based on an engineering study when less restrictive measures, such as automatic gates and channelization devices, are not effective.

**Standard:**

**A Four-Quadrant Gate system shall consist of a series of automatic gates used as an adjunct to flashing-light signals to control traffic on all lanes entering and exiting the highway-light rail transit grade crossing.**

**The Four-Quadrant Gate system shall consist of a drive mechanism and fully retroreflectorized red- and white-striped gate arms with lights, and which in the down position extends individually across the entrance and exit lanes of highway traffic as shown in Figure 8D-2. Standards contained in Section 10D.02 for flashing-light signals shall be followed for signal specifications, location, and clearance distances.**

**In the normal sequence of operation, unless constant warning time or other advanced system requires otherwise, the flashing-light signals and the lights on the gate arms (in their normal upright positions) shall be activated immediately upon detection of the approaching light rail transit vehicle. The gate arms for the entrance lanes of traffic shall start their downward motion not less than 3 seconds after the flashing-light signals start to operate and shall reach their horizontal position at least 5 seconds before the arrival of the light rail transit vehicle. Exit gate arm activation and downward motion shall be based on timing requirements established by an engineering study of the individual site. The gate arms shall remain in the down position as long as the light rail transit vehicle occupies the highway-light rail transit crossing.**

**When the light rail transit vehicle clears the highway-light rail transit grade crossing, and if no other light rail transit vehicle is detected, the gate arms shall ascend to their upright positions, following which the flashing lights and the lights on the gate arms shall cease operation.**

**Gate arm design, colors, and lighting requirements shall be in accordance with the Standards contained in Section 8D.04.**

**Except as noted in the Option below, the exit gate arms shall be designed to fail-safe in the up position.**

**At locations where gate arms are offset a sufficient distance for vehicles to drive between the entrance and exit gate arms, median islands shall be installed in accordance with the needs established by an engineering study.**

Guidance:

The gate arm should ascend to its upright position in not more than 12 seconds.

Four-Quadrant Gate systems should only be used in locations with constant-warning-time light rail transit vehicle detection.

The operating mode of the exit gates should be determined based upon an engineering study, with input from the affected transit agency.

If the Timed Exit Gate Operating Mode is used, the engineering study, with input from the affected transit agency, should also determine the Exit Gate Clearance Time.

If the Dynamic Exit Gate Operating Mode is used, vehicle intrusion detection devices should be installed to control exit gate operation based on vehicle presence within the minimum track clearance distance.

Regardless of which exit gate operating mode is used, the Exit Gate Clearance Time (see Section 8A.01) should be considered when determining additional time requirements for the Minimum Warning Time.

If a Four-Quadrant Gate system is used at a location that is adjacent to an intersection that could cause vehicles to queue within the minimum track clearance distance, the Dynamic Exit Gate Operating Mode should be used unless an engineering study indicates otherwise.

If a Four-Quadrant Gate system is interconnected with a highway traffic signal, backup or standby power should be considered for the highway traffic signal. Also, circuitry should be installed to prevent the highway traffic signal from leaving the track clearance green interval until all of the gates are lowered.

At locations where sufficient space is available, exit gates should be set back from the track a distance that provides a safety zone long enough to accommodate at least one design vehicle between the exit gate and the nearest rail.

Four-Quadrant Gate systems should include remote health (status) monitoring capable of automatically notifying light rail transit signal maintenance personnel when anomalies have occurred within the system.

Option:

Exit gate arms may fail in the down position if the highway-light rail transit grade crossing is equipped with remote health (status) monitoring.

Four-Quadrant Gate system installations may include median islands between opposing lanes on an approach to a highway-light rail transit grade crossing.

Guidance:

Where sufficient space is available, median islands should be at least 60 ft. in length.

### **Section 10D.05 Traffic Control Signals**

Support:

There are two types of traffic control signals for controlling vehicular and light rail transit movements at interfaces of the two modes. The first is the standard traffic control signal described in Part 4, which is the focus of this section. The other type of signal is referred to as a light rail transit signal and is discussed in Section 10D.07.

**Standard:**

**The provisions of Parts 4 and 8 relating to traffic control signal design, installation, and operation, including interconnection with nearby automatic gates or flashing-light signals, shall be applicable as appropriate where traffic control signals are used at highway-light rail transit grade crossings.**

Guidance:

When a highway-light rail transit grade crossing equipped with a flashing-light signal system is located within 200 ft. of an intersection or midblock location controlled by a traffic control signal, the traffic control signal should be provided with preemption in accordance with Section 4D.13.

Coordination with the flashing-light signal system should be considered for traffic control signals located more than 200 ft. from the crossing. Factors to be considered should include traffic volumes, vehicle mix, vehicle and light rail transit approach speeds, frequency of light rail transit vehicles, and queue lengths.

If the highway traffic signal has emergency vehicle preemption capability, it should be coordinated with light rail transit operation.

Where light rail transit operates in a wide median, vehicles crossing the tracks and being controlled by both near and far side traffic signal faces should receive a protected left-turn green phase from the far side signal face to clear vehicles from the crossing when light rail transit vehicles are approaching the crossing.

Option:

Green indications may be provided during light rail transit phases for vehicle, pedestrian, and bicycle movements that do not conflict with light rail transit movements.

Traffic control signals may be installed in addition to four-quadrant gate systems and automatic gates at a highway-light rail transit crossing if the crossing occurs within a highway-highway intersection and if the traffic control signals meet the warrants described in Chapter 4C.

At a location other than an intersection, when light rail transit speeds are less than 25 mph, traffic control signals alone may be used to control road users at highway-light rail transit grade crossings only when justified by an engineering study.

Typical circumstances may include:

- A. Geometric conditions preclude the installation of highway-light rail transit grade crossing warning devices.
- B. Light rail transit vehicles share the same roadway with road users.
- C. Traffic control signals already exist.

**Support:**

See Section 4D.13 for considerations regarding traffic control signals at or near highway-light rail transit grade crossings that are not equipped with highway-light rail transit grade crossing warning devices.

**Section 10D.06 Highway Traffic Signal Preemption Turning Restrictions****Guidance:**

When a light rail transit grade crossing exists within a signalized intersection, consideration should be given to providing separately controlled Protected Only Mode turn phases for the movements crossing the tracks (see Section 4A.02).

**Standard:**

**Signal faces that are provided for separately controlled Protected Only Mode turn movements toward the crossing shall display a red indication during the approach and/or passage of light rail transit vehicles.**

**Guidance:**

When a signalized intersection that is located within 200 ft. of a highway-light rail transit grade crossing is preempted, all existing turning movements toward the highway-light rail transit grade crossing should be prohibited.

**Support:**

Part 4 contains information regarding signal phasing and timing requirements.

**Option:**

An activated blank-out or changeable message sign and/or an appropriate highway traffic signal display may be used to prohibit turning movements toward the crossing during preemption (see Section 10C.09).

**Standard:**

**Messages on the activated blank-out or changeable message signs shall be visible only when the highway-light rail transit intersection restriction is in effect.**

**Section 10D.07 Use of Traffic Control Signals for Control of Light Rail Transit Vehicles at Grade Crossings****Guidance:**

Light rail transit movements in semiexclusive alignments at nongated grade crossings that are equipped with traffic control signals should be controlled by special light rail transit signal indications.

**Support:**

Examples of light rail transit traffic control signals, used to control light rail transit movements only, are shown in Figure 10D-1.

**Option:**

Standard traffic control signals may be used instead of light rail transit traffic control signals to control the movement of light rail transit vehicles (see Section 10D.05).

**Standard:**

**If a separate set of standard traffic control signal indications (red, yellow, and green circular and arrow indications) is used to control light rail transit movements, the indications shall be positioned so they are not visible to motorists, pedestrians, and bicyclists (see Section 4D.17).**

**If the light rail transit crossing control is separate from the intersection control, the two shall be interconnected. The light rail phase shall not be terminated until after the light rail transit vehicle has cleared the crossing.**

































**Option:**

Light rail transit signals may be used at grade crossings and at intersections in mixed-use alignments in conjunction with standard traffic control signals where special light rail transit signal phases are used to accommodate turning light rail transit vehicles or where additional light rail transit clearance time is desirable.

**Guidance:**

Light rail transit signal faces should be separated vertically or horizontally from the nearest highway traffic signal face for the same approach by at least 3 ft.

**Figure 10D-1. Examples of Light Rail Transit Signals**

	Three-Lens Signal	Two-Lens Signal
<p><b>SINGLE LRT ROUTE</b></p> 	<p>STOP </p> <p>PREPARE TO STOP  <i>Flashing</i></p> <p>GO </p>	<p> STOP</p> <p><sup>(2)</sup> GO</p>
<p><b>TWO LRT ROUTE DIVERSION</b></p> 	<p></p> <p> <i>Flashing</i></p> <p> <sup>(1)</sup></p>	<p></p> <p> <sup>(1),(2)</sup></p>
	<p></p> <p><i>Flashing</i> </p> <p> <sup>(1)</sup></p>	<p></p> <p> <sup>(1),(2)</sup></p>
<p><b>THREE LRT ROUTE DIVERSION</b></p> 	<p></p> <p> <i>Flashing</i></p> <p>  <sup>(1)</sup></p>	<p></p> <p>  <sup>(1),(2)</sup></p>

Notes:

All aspects (or signal indications) are white.

(1) Could be in single housing.

(2) "Go" lens may be used in flashing mode to indicate "prepare to stop".

**Section 10D.08 Pedestrian and Bicycle Signals and Crossings****Standard:**

**Pedestrian signals shall be in accordance with Section 4E.04.**

**Guidance:**

Where light rail transit tracks are immediately adjacent to other tracks or a road, pedestrian signalization should be designed to avoid having pedestrians wait between sets of tracks or between the tracks and the road. If adequate space exists for a pedestrian refuge and is justified based on engineering judgment, additional pedestrian signal indicators, signing, and detectors should be installed (see Section 4E.08).

Flashing-light signals (see Figure 10D-2) with a Crossbuck (R15-1) sign should be installed at pedestrian and bicycle crossings where an engineering study has determined that the sight distance is not sufficient for pedestrians and bicyclists to complete their crossing prior to the arrival of the light rail transit vehicle at the crossing, or where light rail transit speeds exceed 35 mph.

If an engineering study shows that flashing-light signals alone would not provide sufficient notice of an approaching light rail transit vehicle, the LOOK (R15-8) sign (see Figure 10D-2) and/or pedestrian gates should be considered (see Figures 10D-3, 10D-4, and 10D-5).

**Support:**

A pedestrian gate is similar to an automatic gate except the gate arm is shorter.

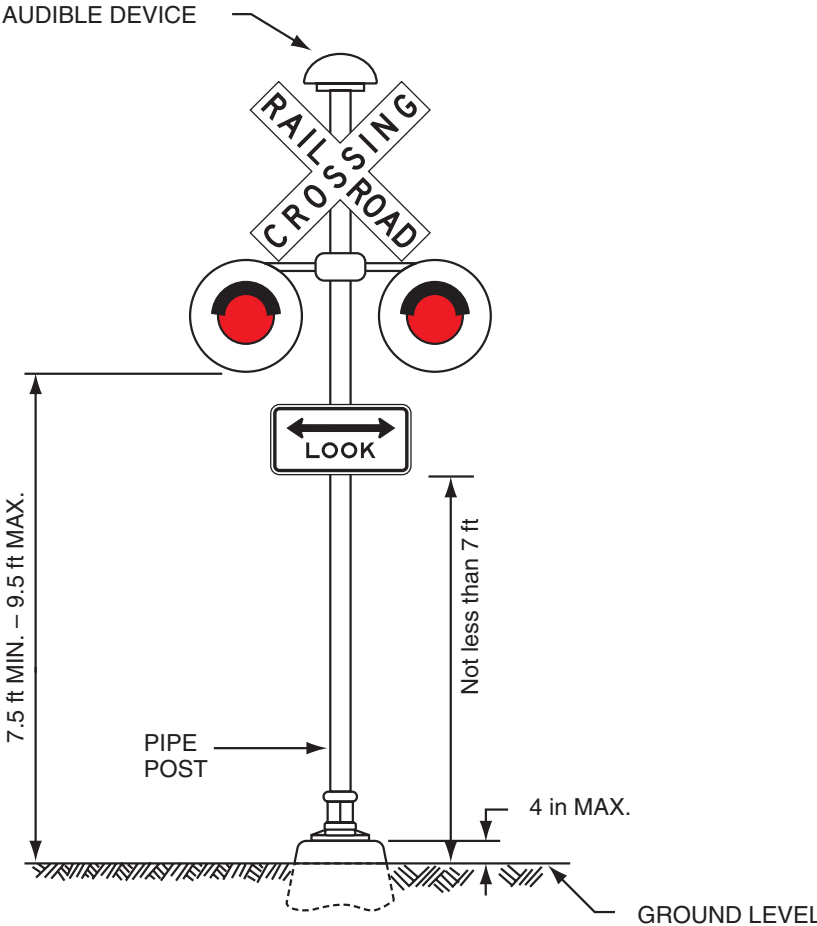
The swing gate alerts pedestrians to the light rail transit tracks that are to be crossed. Swing gates are designed to open away from the tracks, requiring users to pull the gate open to cross, but permitting a quick exit from the trackway, and to automatically close.

**Option:**

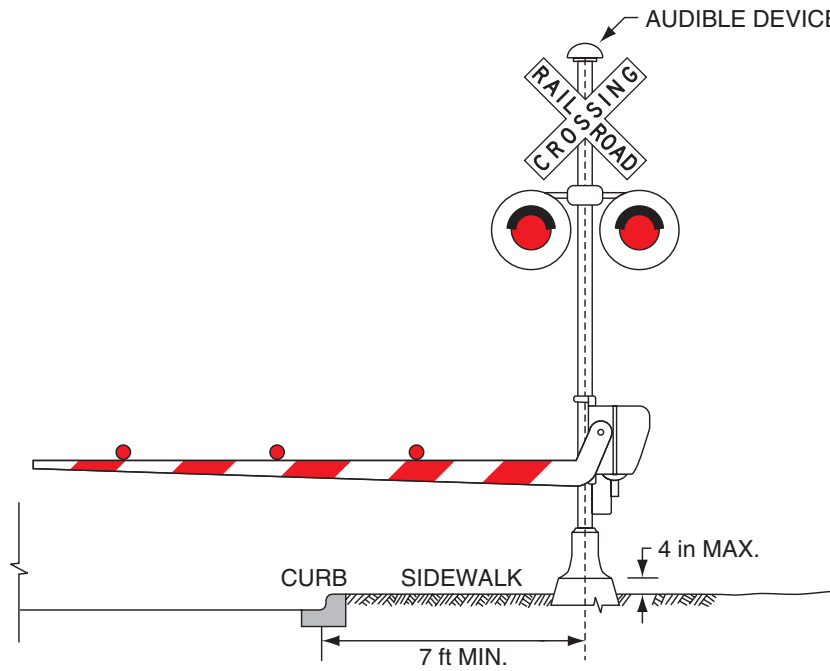
Swing gates may be installed across pedestrian and bicycle walkways (see Figure 10D-6).

Pedestrian barriers at offset crossings may be used at pedestrian and bicycle crossings as passive devices that force users to face approaching light rail transit before entering the trackway (see Figures 10D-7 and 10D-8).

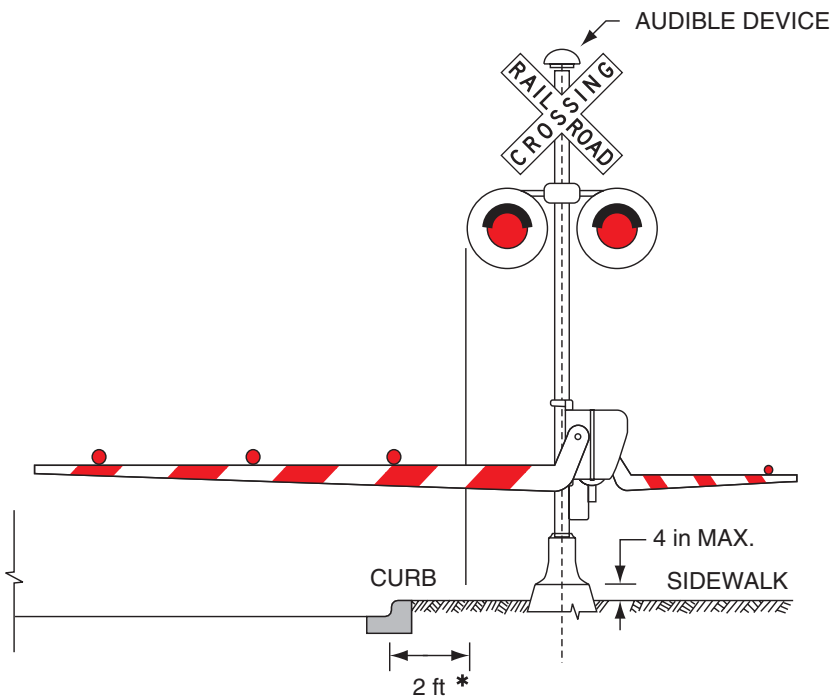
**Figure 10D-2. Example of Light Rail Transit Flashing-Light Signal Assembly for Pedestrian Crossings**



**Figure 10D-3. Example of Pedestrian Gate Placement Behind the Sidewalk**

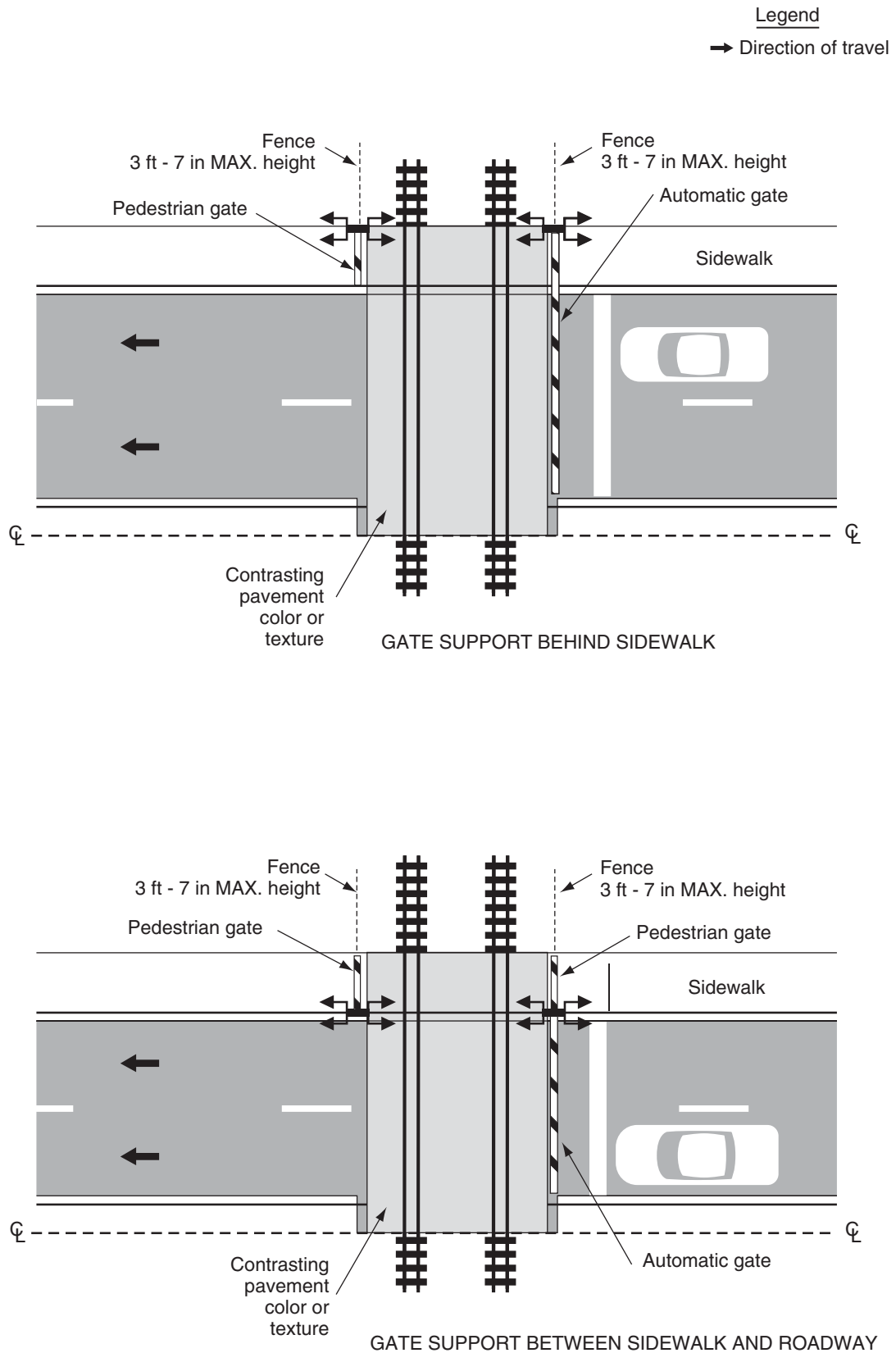


**Figure 10D-4. Example of Pedestrian Gate Placement with Pedestrian Gate Arm**

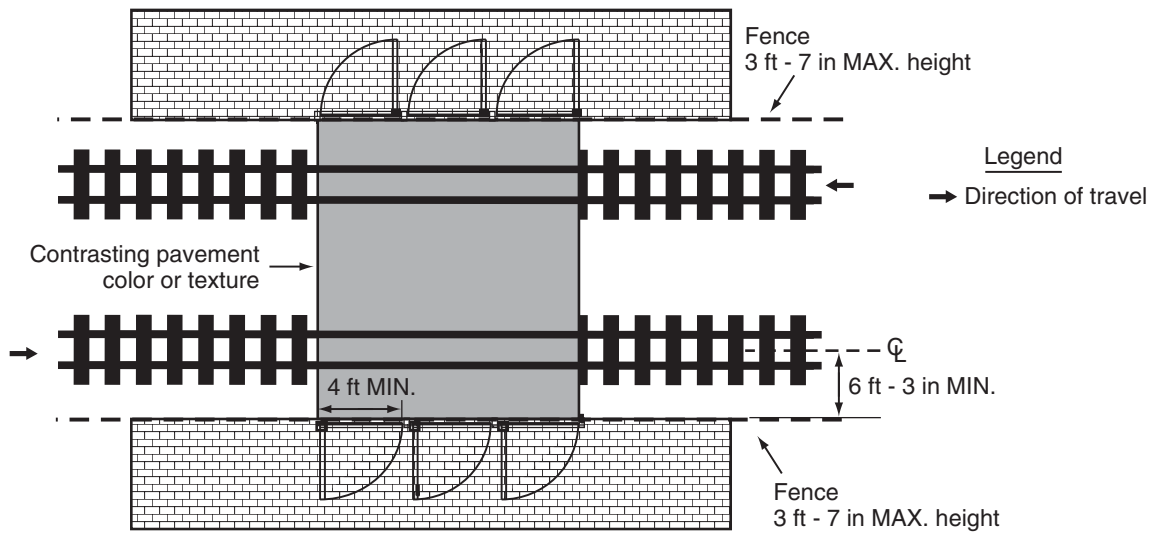


\* For locating this reference line at other than curb section installation, see Section 8D.01.

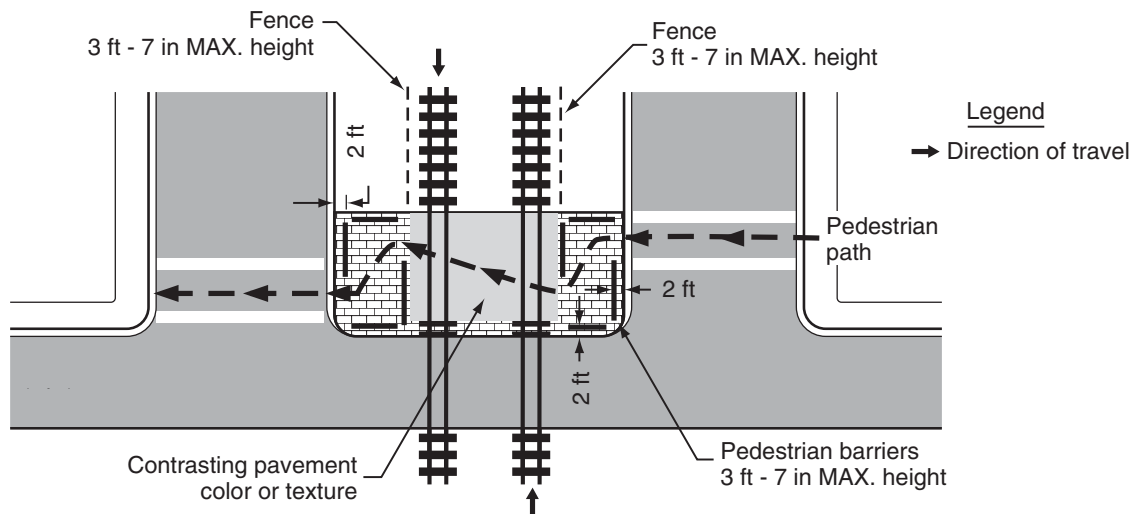
**Figure 10D-5. Examples of Placement of Pedestrian Gates**



**Figure 10D-6. Example of Swing Gates**



**Figure 10D-7. Example of Pedestrian Barriers at an Offset Highway-Light Rail Transit Crossing**



**Figure 10D-8. Examples of Pedestrian Barrier Installation at an Offset Nonintersection Light Rail Transit Crossing**

